

DB01-412-01 SPECIFICATIONS

MATERIAL:

BASEPLATE, FRONT SHIM, AFT SHIM:
.063" AL 2024-T3, AMS-QQ-A-250/5

BACKPLANE:
.050" AL 2024-T3, AMS-QQ-A-250/5

FINISH:

CONVERSION COATING PER MIL-DTL-81706

DESIGN:

- MODIFIED 1/2 ATR SHORT ARINC 404A TRAY
- BACKPLANE SIZED TO FIT 3-GANG ARINC 404 CONNECTOR
- LOCKING LRU HOLD-DOWNS PER M85731
- SOLID RIVET CONSTRUCTION
- PRE-DRILLED MOUNTING HOLES
- ADAPTER WEIGHT: 1.2 LBS

SUPPORT:

3D MODELING AVAILABLE

REV	REVISION DESCRIPTION	DATE	BY
0	INITIAL RELEASE, HARDWARE VERSION 0	06/24/24	NJS

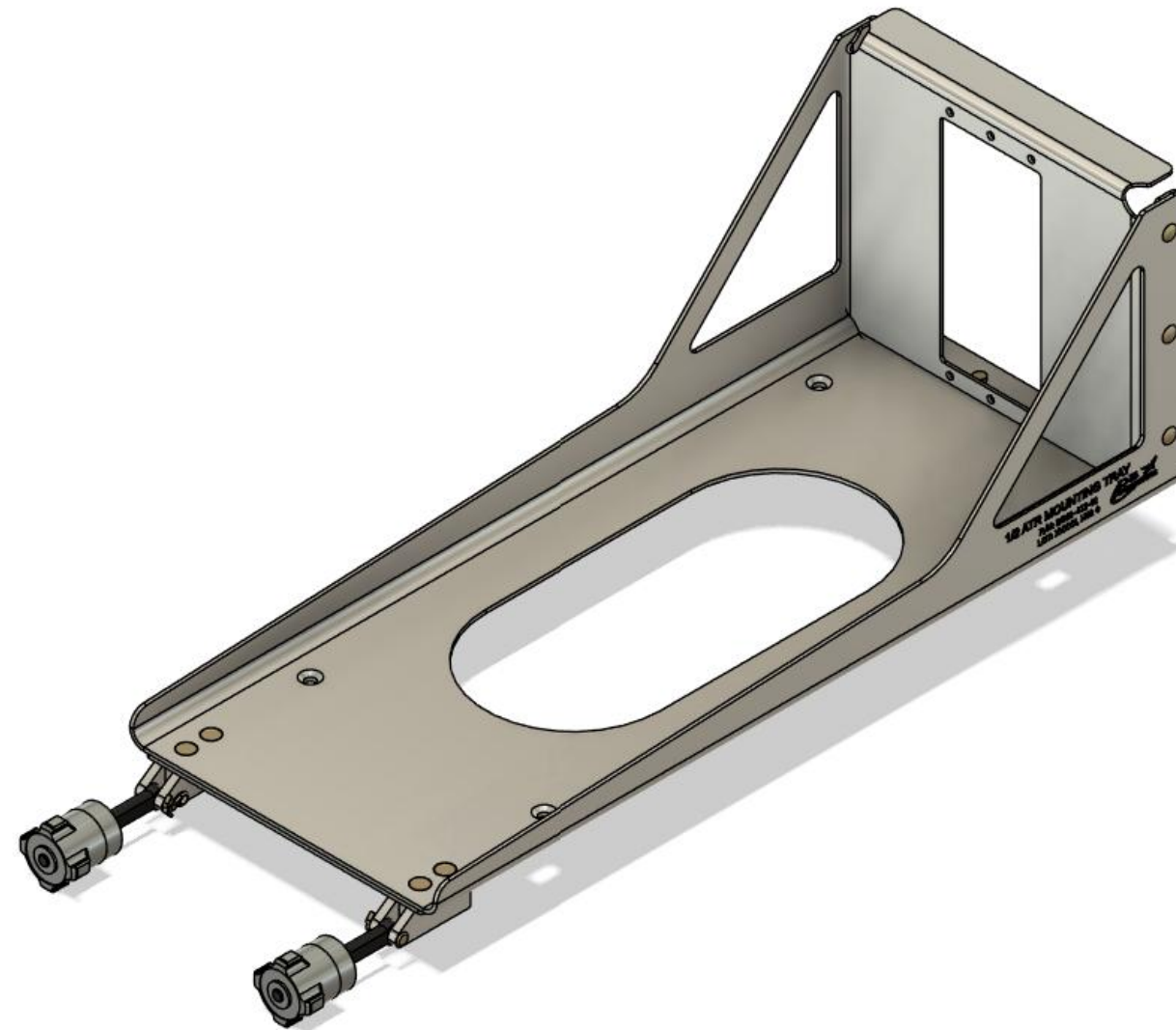

TOLERANCES: X = ± 1.000
.X = ± 0.100
.XX = ± 0.030
.XXX = ± 0.010
ANGLES = ± 2.000
FRACTION = ± 1/32

PROJECT: ARINC 404 TRAY 1/2 ATR SHORT 3-GANG BACKPLANE		 LEHIGH VALLEY, PA
APPROVED: <i>Noah Schultz</i> NOAH SCHULTZ		
TITLE: DB01-412-01 OUTLINE DRAWING	SHEET: 1/2	
DRAWING NO: 240612003	REV: 0	

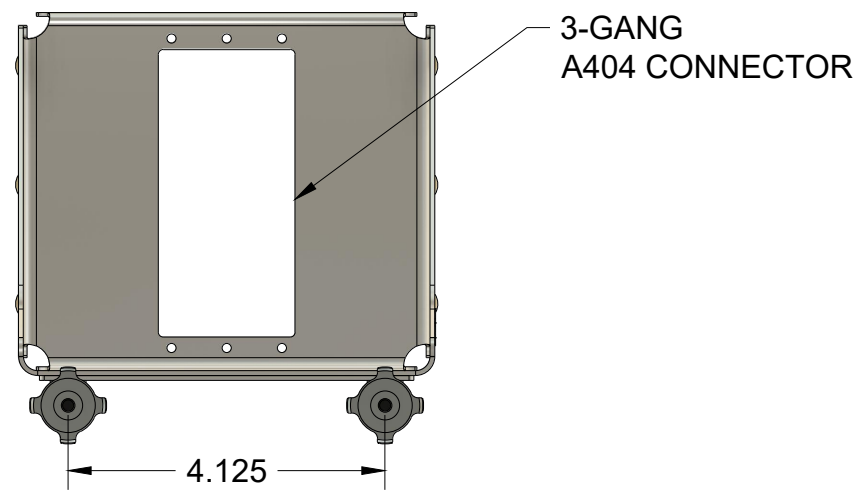
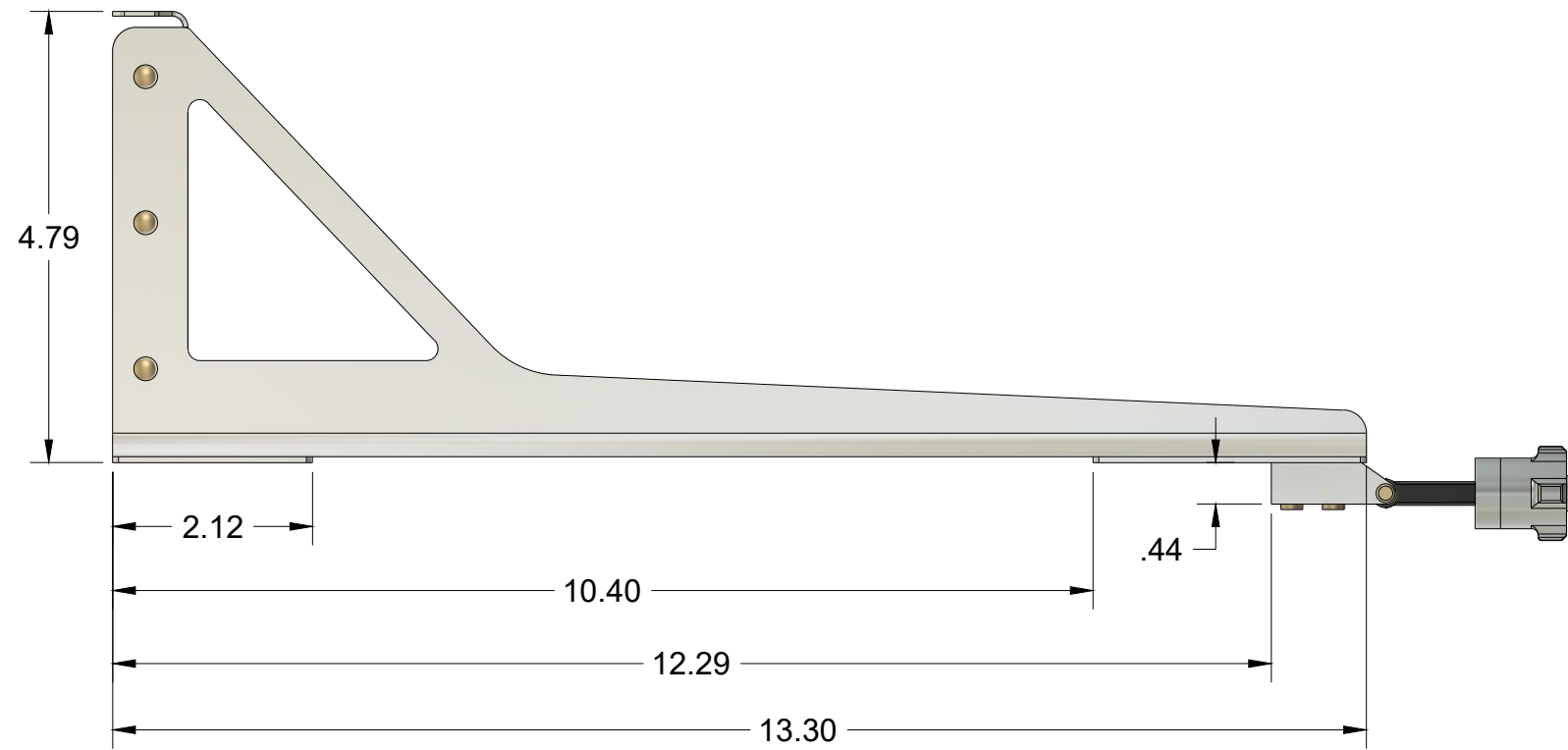
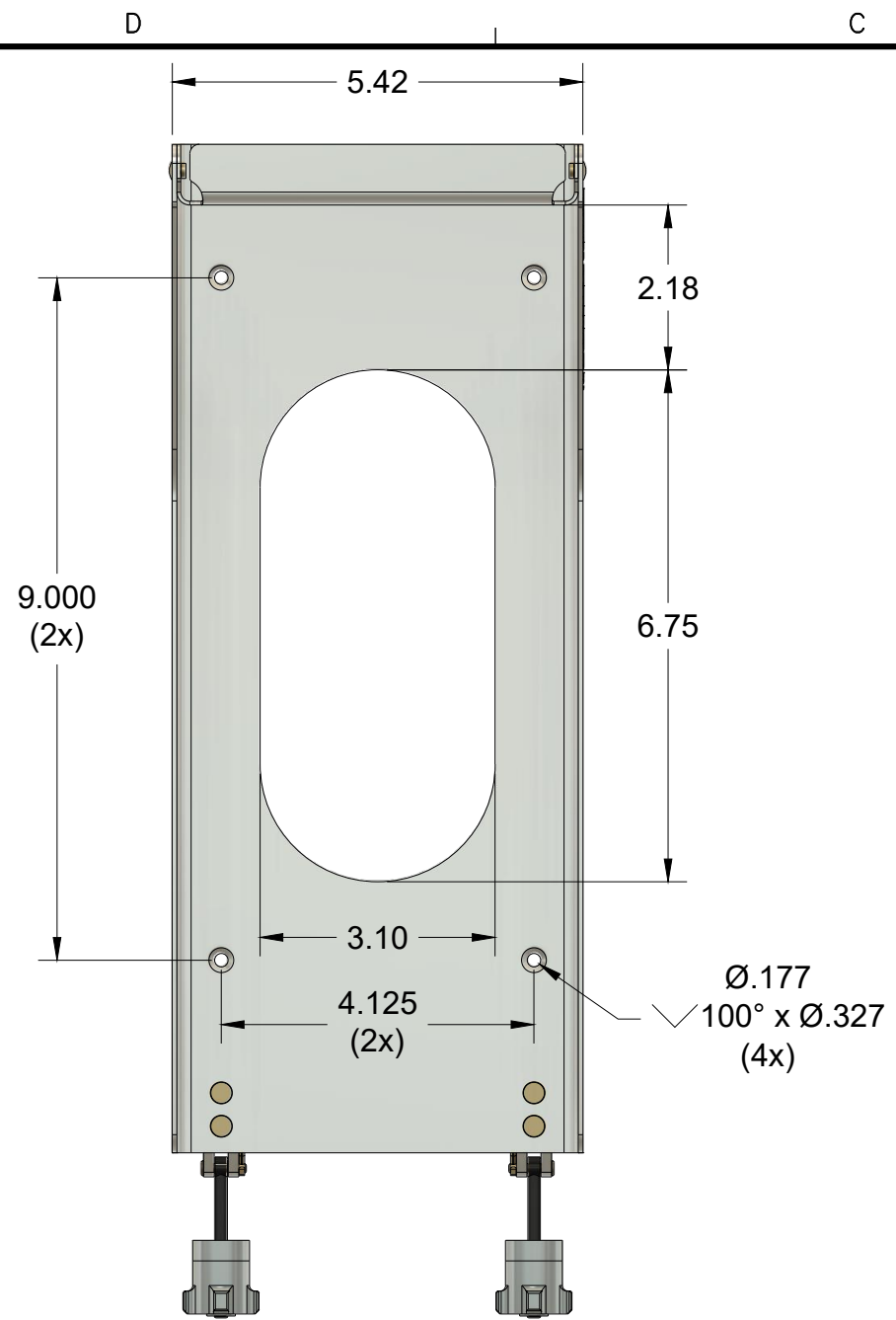

PROJECT: ARINC 404 TRAY 1/2 ATR SHORT 3-GANG BACKPLANE		 LEHIGH VALLEY, PA
APPROVED: SEE SHEET 1		
TITLE: DB01-412-01 OUTLINE DRAWING	SHEET: 2/2	
DRAWING NO: 240612003	REV: 0	